

Captain

Office Seating





Personalità decisa ma equilibrata per Captain, la prima seduta direzionale realizzata da Sinetica per offrire un ambiente completo e coerente, nel comfort come nello stile. Le sue linee sottili e lievemente curve, avvolgono il corpo come un abbraccio. Una piacevole fuga di luce fra il sedile e lo schienale, resa possibile dalla collocazione laterale del meccanismo di regolazione, slancia ulteriormente il suo profilo.

Strong but balanced personality for Captain, the first executive seat created by Sinetica to offer a complete and consistent ambient, within comfort and style. The sleek lines and slightly curved, wrap around the body like a hug. A pleasant escape of light between the seat and back, made possible by the lateral location of the adjustment mechanism, dashes further its profile.

Grand caractère équilibré pour Captain, le premier Fauteuil de direction réalisé par Sinetica pour offrir un aménagement complet et cohérent, du point de vue du confort et du style. Ses lignes fines et légèrement arrondies enveloppent parfaitement le corps. Une agréable ouverture entre l'assise et le dossier, rendue possible grâce à l'emplacement latéral du mécanisme de réglage, en élance ultérieurement le profil.

Captain

Design Baldanzi e Novelli









Captain Soft

Design Baldanzi e Novelli







1



2



3



4



5



6

1
Base 4 razze. Four star base. Piètement par 4. 4er Fusskreuz. Base de 4 radios.

2
Base 4 razze su ruote. Four castors base. Piètement sur roulettes par 4. 4er Fusskreuz mit Rollen. Base de 4 radios con ruedas.

3
Meccanismo. Mechanism. Mecanisme. Mechanick. Mecanismo.

4
Bracciolo. Armrest. Accoudoir. Armlehne. Brazo.

5
Oscillazione schienale. Backrest tilting movement. Oscillation du dossier. rückenlehne Schwingung. Balancearse respaldo.

6
Fessura. Hole. Fente Schlitz. Agujero.

Entschiedener aber ausgewogener Charakter für Captain, dem ersten Sitzmöbel von Sinetica für die Direktion, um sowohl im Komfort als auch im Stil ein komplettes und kohärentes Ambiente anzubieten. Seine schmalen und leicht gebogenen Linien umfassen den Korpus wie eine Umarmung. Die seitliche Unterbringung des Regelmechanismus ermöglicht einen gefälligen Lichtspalt zwischen Sitzfläche und Rückenlehne und streckt sein Profil noch mehr.

Personalidad decidida pero equilibrada para Captain, la primera silla direccional realizada por Sinetica para ofrecer un ambiente completo y coherente, tanto en el confort como en el estilo. Sus líneas delgadas y ligeramente curvas envuelven el cuerpo como en un abrazo. Un agradable hueco de luz entre el asiento y el respaldo, posible gracias a la colocación lateral del mecanismo de regulación, acentúa aún más su perfil.

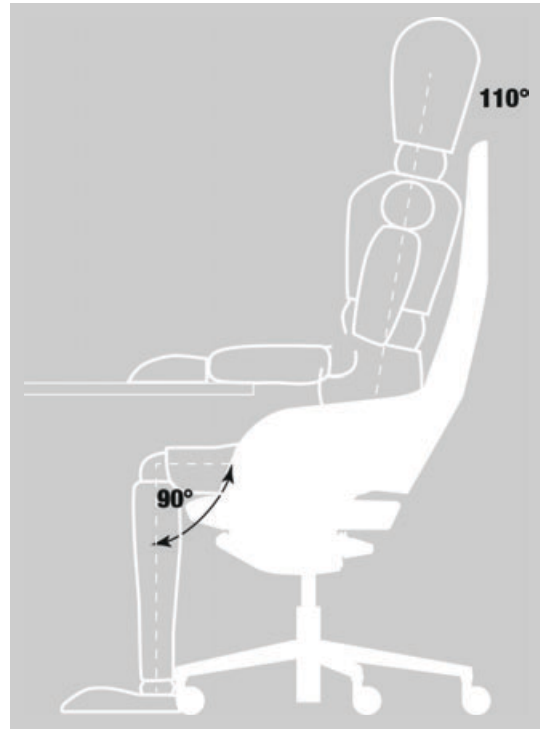
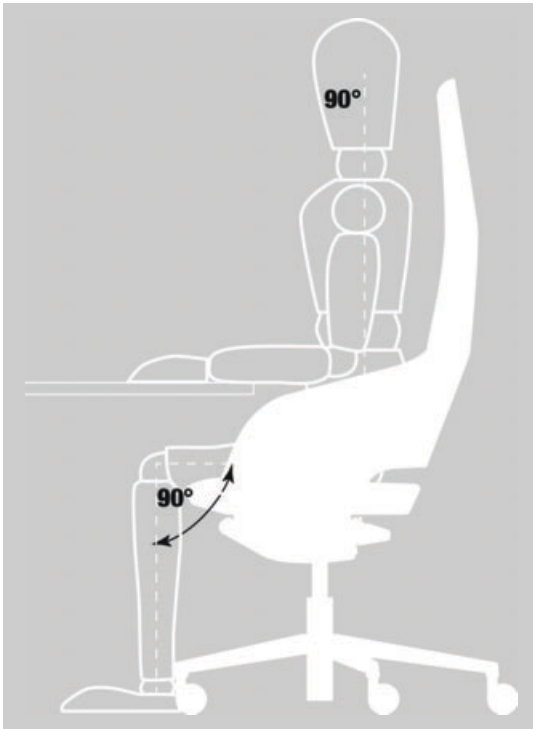

ISTRUZIONI PER L'UTENTE

Manutenzione. Per eliminare polvere e pelucchi è sufficiente passare l'aspirapolvere sul rivestimento. Per togliere eventuali macchie dal rivestimento o dal tessuto a rete, dai braccioli o dalla sottostruttura utilizzare un panno morbido inumidito e un detergente neutro e non aggressivo.

Garanzia ed assistenza. 5 anni di garanzia.

ATTENZIONE! Il prodotto deve essere usato esclusivamente come sedia operativa da ufficio: ogni diverso tipo di utilizzo può essere pericoloso per la vostra incolumità.

USER INFORMATION

Care instructions. Vacuum cleaning suffices to remove dust and fluff from the fabric cover. Please use a damp cloth and a mild, neutral cleaning agent to treat stains on the fabric cover, mesh, armrests or subframe.

Warranty. Warranty 5 years.

PLEASE NOTE! Work on or replacement of gas pressure devices should only be performed by trained specialists. Please be aware that the product should be used as an office work chair only: any other use can be dangerous for your own safety.

REMARQUES

Conseils d'entretien. Pour enlever la poussière et les peluches, il suffit de nettoyer le revêtement tissu à l'aspirateur. Pour enlever des taches sur le revêtement textile ou la résille ainsi que sur les accoudoirs et le piétement, veuillez utiliser un chiffon souple humidifié et un détergent neutre non agressif.

Garantie. 5 ans.

ATTENTION! Le remplacement ou les réparations de la cartouche à gaz ne doivent être effectués que par du personnel qualifié.

Toute utilisation autre que celle engageant un siège de bureau est formellement déconseillée car pouvant être dangereuse pour la sécurité de son utilisateur.

BENUTZERHINWEISE

Pflegehinweise. Absaugen genügt zur Entfernung von Staub und Flusen auf dem Stoffbezug. Bitte verwenden Sie zur Behandlung von Flecken auf dem Stoffbezug oder dem Netzgewebe, den Armlehnen und dem Untergestell ein weiches feuchtes Tuch und ein mildes, neutrales Reinigungsmittel.

Garantie. 5 Jahren.

ACHTUNG! Arbeiten an Gasfedern bzw. deren Austausch dürfen nur durch eingewiesenes Fachpersonal durchgeführt werden. Bitte beachten Sie, dass die Garantie Ihres Bürodrehstuhles nur bei bestimmungsgemäßen Gebrauch gewährt wird.

ADVERTENCIAS PARA EL USUARIO

Pautas de conservación. Basta con aspirar para eliminar el polvo y las pelusas de la tapicería. Limpie las manchas de la tapicería, el tejido de malla, los reposabrazos o la base con un trapo suave humedecido y un producto de limpieza neutro no abrasivo.

Garantía. 5 años.

ADVERTENCIA! La manipulación o sustitución de la suspensión elástica por gas se confiará exclusivamente a personal cualificado. Rogamos tengan en cuenta que el producto se debe usar como silla de trabajo; cualquier otro uso inadecuado podría generar riesgos para su seguridad.



Dimensions & Finishes



Captain

Caratteristiche tecniche

Tecnical characteristic. Caractéristiques techniques. Technische produktarte. Características técnicas.

Seduta. Seduta. Seduta. Seduta. Seduta.

Direzionale

Executive desk
Bureau de direction
Chef-buero
Escritorios
direccionales.



Manageriale

Managerial
Directionel
Management
Direccional

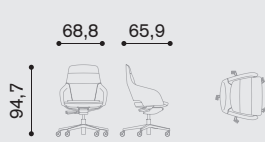
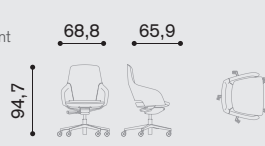

Visitatore

Visitor
Visiteur
Besucher
Visitador

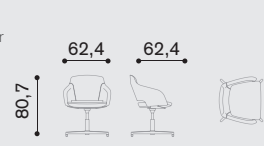

Finiture. Finishes. Finitions. Ausführungen. Acabados.

Tessuto Xtreme

Fabric Xtreme
Tissu Xtreme
Stoff Xtreme
Tejido Xtreme



Tessuto Blazer

Fabric Blazer
Tissu Blazer
Stoff Blazer
Tejido Blazer



Tessuto Denim

Fabric Denim
Tissu Denim
Stoff Denim
Tejido Denim

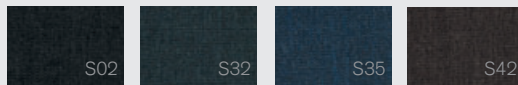

Pelle 1

Leather 1
Cuir 1
Leder 1
Piel 1

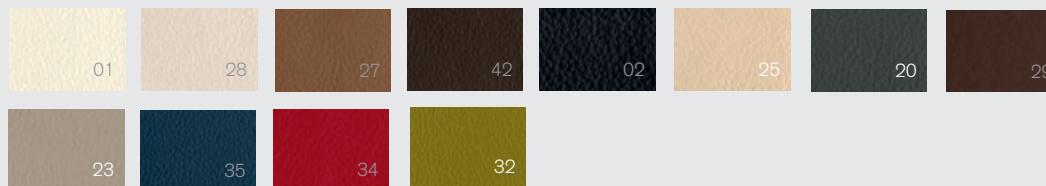

Pelle 2

Leather 2
Cuir 2
Leder 2
Piel 2

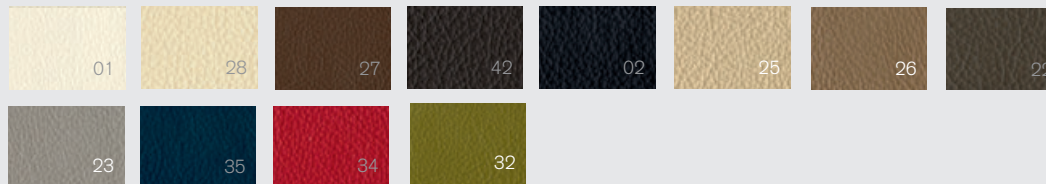

Ecopelle

Simil leather
Similcuir
Kunstleder
Cuero sintético



Meccanismo Synchron

Mechanism Synchron. Mecanisme Synchron.
Mechanick Synchron. Mecanismo Synchron.

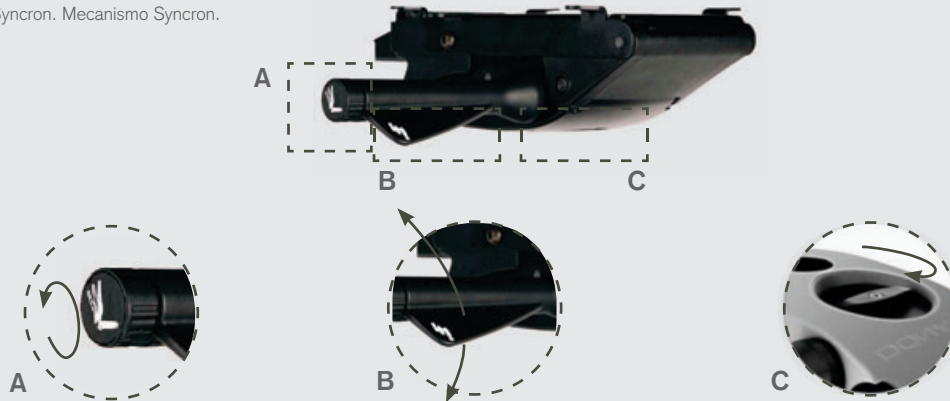

A- 4 posizioni oscillazione. n°4 locking positions. Commande réglage à gaz en hauteur. Höhen-Einstellung der Gas-Drück-Feder. 4 posiciones bloque.

B- Comando gas altezza. Gas height control. Commande réglage à gaz en hauteur. Comando gas altezza. Comando de altura con gas.

C- Regolatore comfort. Comfort regulator. Régulateur de confort. Komfort-Regulator. Regulador de comfort.

Auto return



1

Meccanismo Synchron.

Mechanism Synchron. Mecanisme Synchron.
Mechanick Synchron. Mecanismo Synchron.

Limitatore di corsia in 4 posizioni. n°4 positions limiting device.
Limiteur de course en 4 positions. Positionsschalter auf 4 Stellungen.
Limitador de carrera en 4 posiciones.

Regolatore di comfort in funzione della tipologia di sedia. comfort regulator (depending on the chair typology). Régulateur de confort en fonction de la typologie de la chaise. Komfort-Regulator abhängig der Typologie der Stuhl. Regulador de confort en función de la tipología de silla.

2

Meccanismo Auto-Return.



Mechanism Auto-return. Mecanisme Auto-return. Mechanick Auto-return. Mecanismo Auto-return.

Comando gas altezza. Gas height control. Commande réglage à gaz en hauteur. Comando gas altezza. Comando de altura con gas.

CARATTERISTICHE TECNICHE

Sedute direzionali in versione Alta, media e bassa. Sedile e schienale realizzato con struttura in acciaio ed imbottitura in poliuretano espanso a freddo ignifugo. Rivestimento in tessuto, ecopelle o pelle. Nella versione Captain SOFT sedile e schienale con imbottitura in piumino d'oca. Meccanismo con movimento oscillante auto-pesante, comando per alzata a gas e regolatore di comfort. Base a 4/5 razze in alluminio pressofuso e finitura lucida. Ruote in PA con dischetti laterali cromati e gomma antimacchia. Piedini in PA nero.

TECNICAL CHARACTERISTIC

Directional chairs in the high, medium and low versions. Chair and back rest made with a steel structure and upholstered with a flame-retardant polyurethane foam. Covered in fabric, artificial leather or leather. Mechanism with rocking motion, gas lift command and comfort regulator. 4/5 spoke base in cast polished aluminum. PA wheels with chromed lateral disks and anti-scratch rubber. Black PA feet.

CARACTÉRISTIQUES TECHNIQUES

Sièges directionnels en version haute, moyenne et basse. Sièges et dossiers réalisés avec une structure en acier et rembourrés en polyuréthane expansé à froid ignifuge. Revêtus de tissu, de faux cuir ou de cuir. Version Captain Soft avec assise et dossier en duvet rembourrés de duvet d'oie. Mécanisme avec mouvement oscillant autopessant, commande de levée à gaz et régulateur de confort. Piètement à 4/5 branches en aluminium moulé sous pression et finition brillante. Roulettes en PA avec disques latéraux chromés et en gomme anti tâches. Pieds en PA noir.

TECHNISCHE PRODUKTARTE

Direktionssessel in der Ausführung hoch, mittel oder niedrig. Sitzfläche und Rückenlehne aus Stahlrahmen mit Polsterung aus feuerbeständigem Polyurethankaltschaum. Bezug aus Stoff, synthetischem Leder oder Leder. In der "Captain Soft" Sitz und Rücken mit Gänse- Daunen gepolstert sind. Schwingmechanismus mit automatischer Einstellung auf das Gewicht, Höheneinstellung durch Gasfeder und Komfortregler. Fuß mit 4/5 Speichen aus Aluminiumdruckguss in glänzender Ausführung. Rollen aus PA mit verchromten Seitenscheiben und Schmutz abweisendem Gummi. Füße aus schwarzem PA.

CARACTERÍSTICAS TÉCNICAS

Sillas directivas en versión alta, media y baja. Asiento y respaldo realizados con estructura de acero y relleno de poliuretano expandido en frío ignifugo. Revestimiento en tejido, ecopiel o piel. Versión Soft Asiento y respaldo acolchado de plumas de ganso. Mecanismo con movimiento oscilante autopesante, mando para regular la altura a gas y regulador de confort. Base de 4/5 radios de aluminio fundido bajo presión y acabado brillante. Ruedas en PA con discos laterales cromados y goma antimancha. Patas de PA negro.