

Frame + System

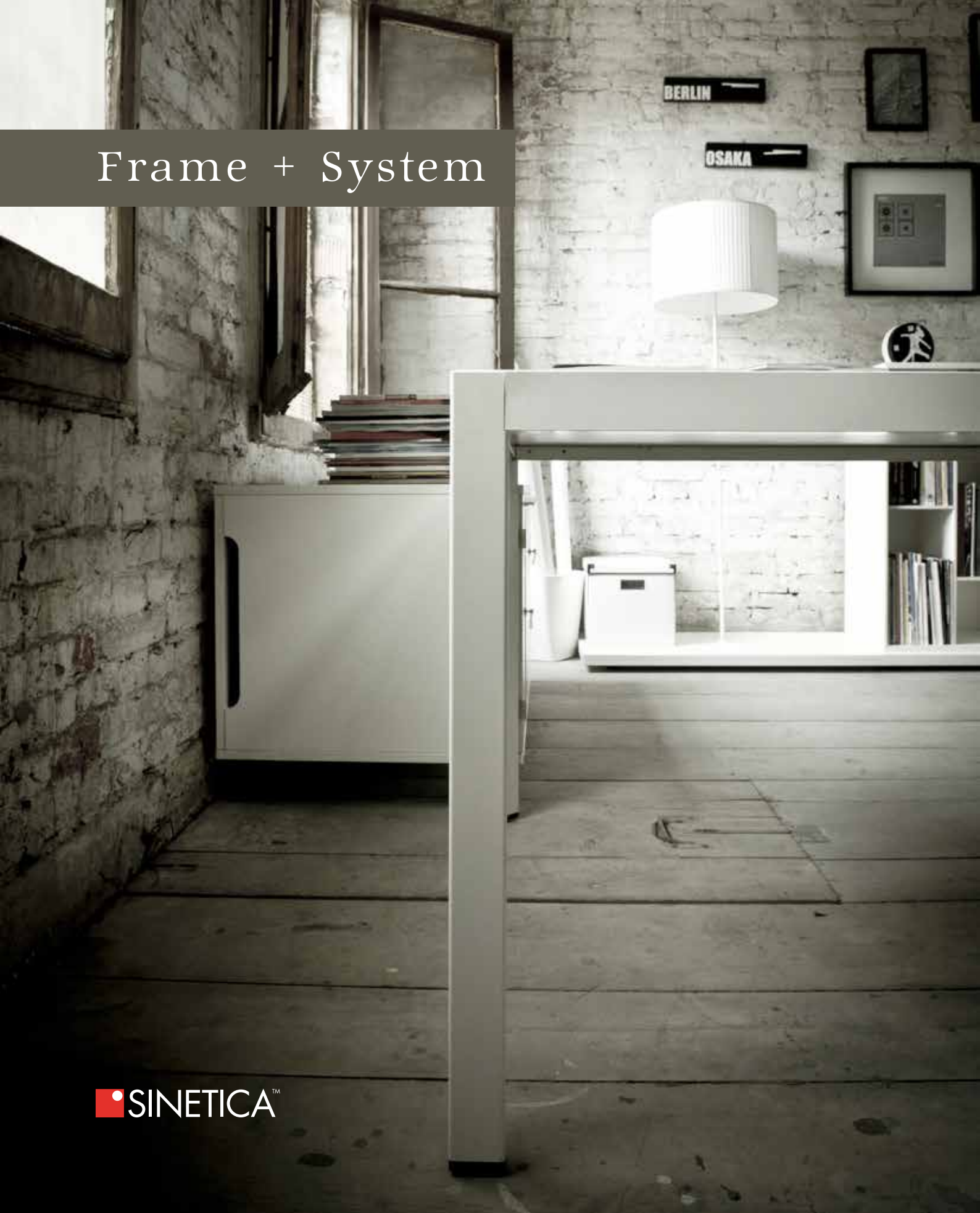



Frame + System

Frame + System Contents

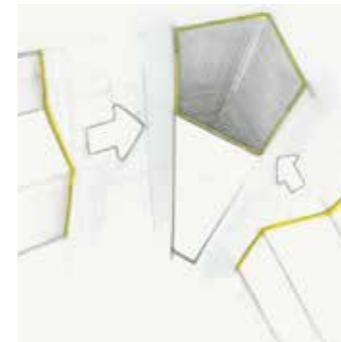

#Design p.4



#Industrial p.6



#Urban p.28



#Trendy p.38



#Innovative p.56



#Dimensions&Finishes p.56

#Design

Fascinating project.

Un progetto che dà più flessibilità, più possibilità, più eleganza all'ufficio contemporaneo, nel segno di un affascinante minimalismo. In qualsiasi cornice architettonica e stilistica, per ogni esigenza di lavoro: dall'ufficio operativo, agli ambienti direzionali, agli spazi meeting. È Frame +, un sistema trasversale che trova la sua identità nella struttura perimetrale in alluminio con piano integrato. Un elemento caratterizzante e funzionale al tempo stesso, pensato per dare vita a composizioni senza limiti, grazie alla sua intrinseca versatilità ed a una gamma completa di accessori e complementi d'arredo. Un'idea di design che si materializza in soluzioni ogni volta diverse, vestendosi di sensazioni materiche e cromatiche, emozioni naturali o glamour, conciliando estetica e benessere, prestigio ed essenzialità. Una qualità del progetto che diventa qualità della vita: con Sinetica.

A project that gives the modern office added flexibility and options and more elegance with a fascinating minimalist touch. Whatever the architectural or stylistic setting, whatever need you may have for the working space: from the administrative and executive office environment to meeting rooms. Frame +, a universal system that finds its identity in the surrounding aluminium structure with integrated floor. One of its distinctive while yet practical elements, conceived for limitless space arrangements, thanks to its intrinsic versatility and a full range of accessories and furnishing items. A designer concept that translates into solutions that are different each time and that time again find material and colourful expression, giving a natural or glamorous vibe that craftily blends aesthetic appeal with wellness, prestige and essentiality in one. Project quality becomes quality of life: meet Sinetica.

Un projet qui vous donne plus de flexibilité, plus de possibilités, plus d'élégance au bureau contemporain, dans le signe d'un minimalisme fascinant. Dans n'importe quel contexte architectural et stylistique, pour toutes les exigences de travail : du bureau d'exploitation, aux bureaux de direction, aux espaces de réunion. Frame + est un système à grande échelle qui trouve son identité dans la structure périphérique en aluminium avec plan intégré. Un trait distinctif et fonctionnel en même temps, conçu pour créer des compositions sans limites, en raison de sa polyvalence inhérente et une gamme complète d'accessoires et d'articles d'ameublement. Une idée de conception qui se matérialise dans les solutions à chaque fois différentes, qui s'habille de sensations matérielles et chromatiques, des émotions naturelles ou fascinante, en conciliant beauté et bien-être, luxe et simplicité. Un projet de qualité qui devient qualité de vie : avec Sinetica.

Ein Projekt, das mit einem faszinierenden Minimalismus mehr Flexibilität, mehr Möglichkeiten, mehr Eleganz in das moderne Büro bringt. In jeden architektonischen und stilistischen Rahmen, für jede Arbeitsanforderung - vom Arbeitsbüro bis zu den Direktionsräumen und Meetingsälen: Das ist Frame +, ein transversales Projekt, das seine Identität in der Aussenstruktur aus Aluminium mit integrierter Arbeitsfläche findet. Ein charakteristisches und gleichzeitig funktionales Element, entworfen, um mit seiner innwohnenden Vielseitigkeit zusammen mit einer kompletten Auswahl an Zubehör und Einrichtungselementen eine unbegrenzte Zahl an Kompositionen zu schaffen. Eine Designidee, die den Stoff für immer wieder neue Lösungen in sich trägt, die sich mit plastischen und farbigen Erlebnissen, natürlichen und glamourösen Emotionen einhüllt und Ästhetik und Wohlbefinden, Prestige und Essenz in Einklang bringt. Projektqualität wird zu Lebensqualität - mit Sinetica.

Un proyecto que da más flexibilidad, más posibilidades, más elegancia a la oficina contemporánea, en una señal de fascinante minimalismo. En cualquier entorno arquitectónico y estilístico, para cualquier exigencia de trabajo: desde las oficinas operativas, los entornos ejecutivos, los espacios de encuentro. Es Frame +, un sistema transversal que encuentra su identidad en la estructura perimetral en aluminio con plan integrado. Un elemento característico y funcional al mismo tiempo, pensado para dar vida a composiciones sin límites, gracias a su versatilidad inherente y a una gama completa de accesorios y complementos para el hogar. Una idea de diseño que se materializa en soluciones cada vez más diferentes, vistiendo sensaciones de material y color, emociones naturales combinando estética y bienestar, lujo y simplicidad. Una calidad del proyecto que se convierte en calidad de vida: con Sinetica.

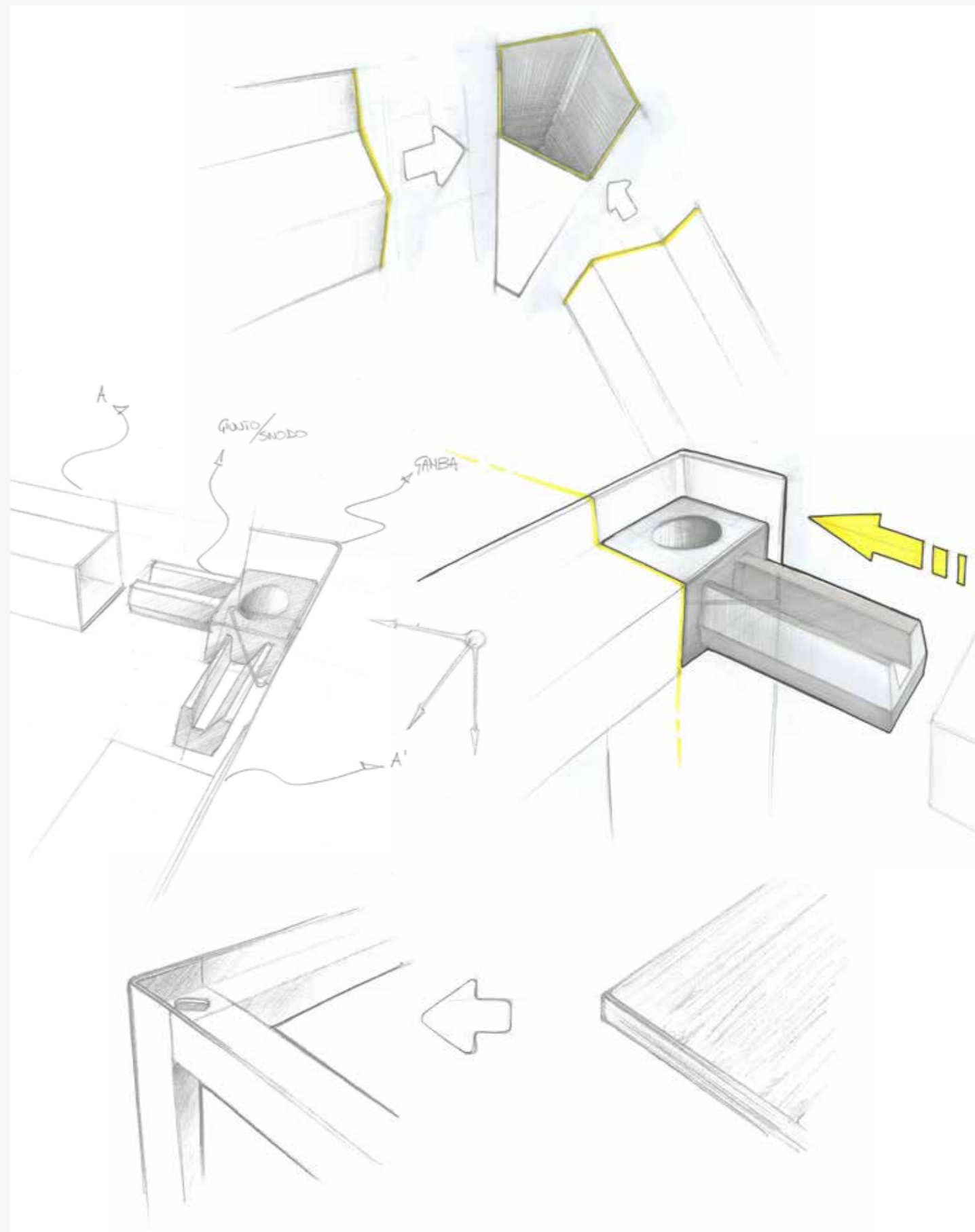

#Industrial

Creative factory.

Pareti di mattoni a vista, pavimenti di legno grezzo, ampie vetrate, altissimi soffitti, spazi aperti che lasciano una completa libertà di movimento e di lavoro. È l'opificio, un luogo che racconta la storia affascinante della cultura industriale del XX secolo, ma che al tempo stesso può diventare lo scenario di un pensiero dinamico e creativo, un modo non convenzionale di intendere la propria attività. In questo palcoscenico, fra memoria e attualità, Frame + dimostra il suo carattere da protagonista, interpretando molteplici ruoli. Dallo studio del leader, alle soluzioni per il lavoro di gruppo, allo spazio dedicato alle riunioni. Sempre in armonia con ogni situazione ed esigenza, ma con un contenuto di fascino e di classe in più.

Open-view brick walls, coarse wood floors, spacious glass panels, sky-scraping ceilings, open space for comfortable moving about and work. Meet the old-fashioned factory that tells the fascinating history of industrial culture in the 20th century, but that instantly shapeshifts to dynamic and creative think tank, an unconventional way of interpreting business. Somewhere between traditional and contemporary, Frame + proves a star in a variety of roles. From the CEO's office, to teamwork solutions, to the meeting room. Always in tune with every situation and requirement, but with an extra touch of elegance and class.













Les murs de briques apparentes, les planchers en bois brut, les grandes fenêtres, les hauts plafonds, les espaces ouverts qui permettent une totale liberté de mouvement et de travail.

Et l'usine de tissage, un lieu qui raconte l'histoire fascinante de la culture industrielle du XXe siècle, mais en même temps qui peut devenir le théâtre d'une réflexion dynamique et créative, de façon non conventionnelle de concevoir l'entreprise.

Dans ce contexte, entre la mémoire et le présent, Frame + démontre son caractère de protagoniste, jouant des rôles multiples. Du studio du chef, aux solutions pour le travail de groupe, à l'espace dédié aux réunions. Toujours en harmonie avec toutes les situations et besoins, mais avec une touche de charme et de classe.

Wände aus Backstein, Fußböden aus Rohholz, weite Glasfronten, sehr hohe Decken, offene Räume, die eine vollständige Bewegungs- und Arbeitsfreiheit lassen.

Es ist eine Produktionsstätte, ein Ort, der die faszinierende Geschichte der Industriekultur des 20. Jahrhundert erzählt, der jedoch im gleichen Moment zum Szenarium für einen dynamischen und kreativen Gedanken, eine unkonventionelle Art sein eigenes Unternehmen zu sehen, wird.

Auf dieser Bühne, zwischen Gestern und Heute, zeigt Frame + sein Wesen als Hauptdarsteller, der eine Vielzahl an Rollen übernimmt. Vom Managerbüro zu Lösungen für die Gruppenarbeit, zum Raum für Sitzungen und Seminare. Immer in Harmonie mit jeder Situation und Anforderung, immer mit einem Plus an Faszination und Klasse.











Paredes de ladrillo expuesto, suelos de madera ásperos, grandes ventanales, techos altos, espacios abiertos que permiten una completa libertad de movimiento y de trabajo.

La fábrica es, un lugar que cuenta la fascinante historia de la cultura industrial del siglo XX, pero que al mismo tiempo puede convertirse en el escenario de un pensamiento dinámico y creativo, una forma nada convencional de entender su actividad.

En este escenario, entre memoria y actualidad, Frame + demuestra su personaje, interpretando múltiples papeles. Desde el estudio del líder, a las soluciones para el trabajo en grupo, al espacio dedicado a las reuniones. Siempre en armonía con cada situación y necesidad, pero con un contenido de encanto y clase.

#Urban

Contemporary architecture.

Uno spazio di lavoro concepito come un'opera di interior design, un esperimento di sintesi fra le tipologie dell'ufficio open space, lo show room e ambiente living. In un loft prestigioso, all'interno di un'architettura residenziale, calde atmosfere domestiche e dinamiche atmosfere lavorative si incontrano e si fondono, all'insegna della contemporaneità, della tecnologia ma anche dell'ecosostenibilità, del benessere, del piacere di lavorare e di vivere insieme. Un concept originale e innovativo, nel quale il sistema Frame + si trova perfettamente a proprio agio, risolvendo ogni necessità con uno stile impeccabile e con una flessibilità totale. Dall'ufficio operativo, alle situazioni direzionali, alla sala riunioni, insieme agli altri elementi e complementi d'arredo della collezione Sinetica.

A business environment conceived as work of interior design, a throw at combining the open space, showroom and living ambient. In a prestigious loft, part of residential architecture, cosy home interiors and dynamic office spaces meet and blend in the sign of modern design and technology, eco-friendly, relaxing, stimulating teamwork and living together. A creative and pioneering concept where the Frame + system is in its natural habitat, catering to your particular need with flawless style and total flexibility. From the administrative and executive office to the meeting room, along with the other furnishing accessories of the Sinetica collection.











Un espace de travail conçu comme un travail de design d'intérieur, une expérience de la synthèse entre le type de bureau espace ouvert, la salle d'exposition et l'espace habité.

Dans un loft prestigieux, à l'intérieur d'une architecture résidentielle, l'atmosphère chaleureuse de la maison et les atmosphères de travail dynamiques se rencontrent et se confondent, au nom de la modernité, mais aussi des écotecnologies, du bien-être, du plaisir de travailler et de vivre ensemble.

Un concept original et novateur, dans lequel le système Frame + se trouve parfaitement à l'aise, en résolvant tous les besoins avec un style impeccable et avec une totale flexibilité. Du bureau d'exploitation, aux situations de direction, à la salle de réunion, ainsi que d'autres éléments et compléments d'ameublement de la collection Sinetica.

Eine Arbeitsstätte, die als ein Kunstwerk des Innendesign gedacht ist, ein Experiment der Synthese zwischen einem offenen Büroraum, Show room und Wohnraum. In einem eindrucksvollen Loft treffen in einer Wohnarchitektur warme häusliche Atmosphäre und dynamische Arbeitsatmosphäre aufeinander und vermischen sich im Zeichen der Moderne, der Technologie, der Umweltfreundlichkeit, dem Wohlfühl und der Gesundheit zur Freude am Arbeiten und am Leben. Ein originelles und innovatives Konzept, in das sich Frame + perfekt einfügt und für jede Anforderung im tadellosen Stil und mit einer totalen Flexibilität eine Lösung findet: vom Arbeitsbüro, zu Direktionsräumen und Meetingssälen - in Kombination mit den anderen Elementen und Einrichtungsergänzungen der Kollektion Sintetica.

Un espacio de trabajo concebido como una obra de diseño interior, un experimento de síntesis entre los tipos de oficinas de espacio abierto, la sala de exposiciones y ambiente living.

En un loft prestigioso, dentro de una arquitectura residencial, cálidas atmósferas domésticas y dinámicas atmósferas de trabajo se encuentran y se fusionan, en nombre de la modernidad, de la tecnología pero también de la eco-sostenibilidad, del bienestar, del placer de trabar y vivir juntos. Un concepto original e innovador, en el cual el sistema Frame + se encuentra perfectamente a gusto, resolviendo cada necesidad con un estilo impecable y con una flexibilidad total. Desde la oficina de trabajo, a las situaciones de dirección, a las salas de reuniones, junto a los otros elementos y complementos de colección de Sinetica.

#Trendy

Personal lifestyle.

Romantic, colorato, rigoroso, nomade...
l'ufficio contemporaneo può seguire
molteplici stili. Il sistema Frame + nasce
dallo studio delle nuove tendenze
dell'arredo e grazie alla sua versatilità,
consente di valorizzare ogni ambiente e
personalità, con soluzioni ogni volta diverse
e personalizzate.

Composizioni che ottimizzano lo spazio a
disposizione, creano atmosfere particolari,
impiegano le capacità espressive del
colore oppure le tonalità luminose
o profonde delle essenze, come un
linguaggio affascinante e senza confini.

In un ufficio operativo come un atelier
creativo, un ambiente direzionale o
un home office, uno spazio dedicato
ai meeting di lavoro o agli incontri
informali. Non c'è limite alle possibilità di
rappresentare il proprio stile di vita e di
lavoro, con Frame +.

Romantic, colourful, sombre, nomad...
the contemporary office in a variety of
styles. The Frame + system is the fruit of
research on the latest furnishing trends
and, owing to its modularity, allows you
to make the most of any space and fully
express any personality, offering different
and customized solutions.

Ideal space arrangement creates a special
atmosphere, employing colour or bright
and deep essential nuances as though
they were a form of fascinating and
boundless speech.

Be it an administrative office or designer
studio, an executive or home office, a
meeting room or informal gathering place.
There practically is no limit to the options
of expressing your style of life and work
with Frame +.

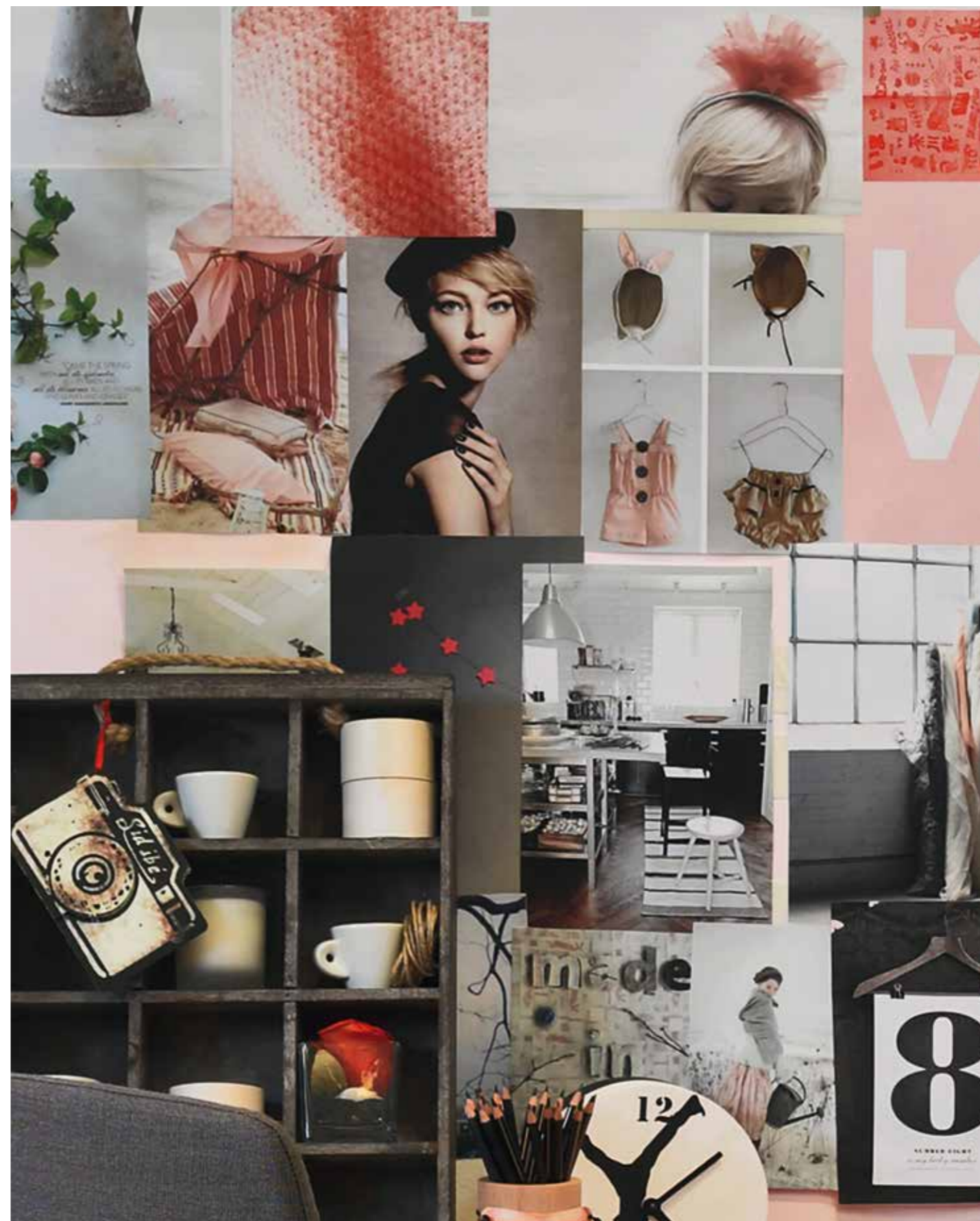



Romantique, coloré, rigoureux, nomade... le bureau contemporain peut suivre des styles multiples. Le système Frame + provient de l'étude des nouvelles tendances en matière de mobilier et, grâce à sa polyvalence, vous permet d'améliorer n'importe quel environnement et personnalité, avec des solutions différentes et personnalisées à chaque fois. Compositions qui optimisent l'espace disponible, créent une ambiance, utilisent les capacités expressives de la couleur ou les tonalités lumineuses ou profondes des essences, comme un langage fascinant et sans limites. Dans un bureau fonctionnant comme un atelier de création, un environnement de dirigeant ou un bureau à domicile, un espace dédié aux réunions d'affaires ou aux réunions informelles. Il n'y a pas de limite aux possibilités de représenter son propre style de vie et de travail avec Frame +.









Romantisch, farbenfroh, streng, Ethnolook...das moderne Büro kann vielen Stilen folgen. Das System Frame + entspringt dem eingehenden Studium der neuen Einrichtungstendenzen und dank seiner Vielseitigkeit kann es auf jede Umgebung, jede Persönlichkeit abgestimmt werden, mit individuellen Lösungen, die jedesmal anders sind. Kompositionen, die den zur Verfügung stehenden Raum optimal ausnutzen, besondere Atmosphären schaffen, sich der expressiven Kraft der Farben oder der leuchten Tonalität oder der Tiefe der Essenzen bedienen, wie einer faszinierenden Sprache ohne Grenzen. In einem Arbeitsbüro, einem Kreativatelier, in Führungsräumen oder dem Büro zu Hause, ein Raum für Arbeitssitzungen und informelle Treffen. Die Möglichkeiten seinen Lebensstil und Arbeitsstil zu verwirklichen, sind mit Frame + unendlich.







Romántico, colorido, riguroso, nómada... la oficina contemporánea puede seguir múltiples estilos. El sistema Frame + nace del estudio de las nuevas tendencias de mobiliario y gracias a su versatilidad, permite mejorar cualquier entorno y personalidad, con soluciones cada vez más diferentes y personalizadas. Composiciones que optimizan el espacio disponible, crean atmósferas especiales, usan las capacidades expresivas del color o bien los tonos luminosos o profundos de las esencias, como un fascinante lenguaje y sin fronteras. En una oficina que opera como un taller creativo, un entorno ejecutivo o una oficina en casa, un espacio dedicado a las reuniones de trabajo o informales. No hay límite a las posibilidades de representar su estilo de vida y de trabajo, con Frame +.

#Innovative

Modern minimalism.

Un nuovo concetto di ufficio, nel quale le tecnologie più all'avanguardia si fondono con una rinnovata attenzione per il benessere e la natura. Un prestigio che non è ostentazione superficiale, ma al contrario ricerca di armonia, attenzione ai dettagli, gusto per gli abbinamenti. Una semplicità che nasce da uno studio approfondito e che si manifesta in composizioni importanti, così come in situazioni di lavoro intime e accoglienti. Trasparenza, solarità, forme pure, essenze naturali: è lo spazio di lavoro del presente e del futuro, in un'ulteriore interpretazione del progetto Frame +.

Dagli ambienti meeting alle situazioni direzionali, insieme agli altri elementi della collezione Sinetica, per dare valori più profondi, più autentici e più emozionanti agli spazi nei quali lavoriamo ogni giorno.

A new office concept where cutting edge technology blends with a revamped care for wellness and nature. Elegance that is never a shallow desire to show off, but rather a quest for harmony, care for detail, tasteful decorating. A carefully studied simplicity that takes shape in impressive space arrangements, just as in discreet and inviting work environments.

Transparency, radiance, pure form, natural essence: the workspace of today and tomorrow, yet another interpretation of the Frame + project.

From meeting rooms to the executive office, along with all the other options of the Sinetica collection, designed to add a deeper, more genuine and engrossing touch to the space we work in every day.







Un nouveau concept de bureau, dont les technologies les plus avancées se fondent avec une attention renouvelée sur le bien-être et la nature. Un prestige qui n'est pas ostentation superficielle, mais plutôt recherche de l'harmonie, attention au détail, goût pour l'assortiment. Une simplicité qui provient d'une étude approfondie et qui se manifeste dans des compositions importantes, ainsi que dans des situations de travail chaleureuses et accueillantes. Transparence, luminosité, des formes pures, essences naturelles : C'est l'espace de travail du présent et de l'avenir, une interprétation plus poussée du projet Frame +.

Des environnements répondant aux situations de direction, ainsi que d'autres éléments de la collection Sinetica, pour donner des valeurs plus profondes, plus authentiques et plus excitantes aux espaces dans lesquels nous travaillons tous les jours.



Ein neues Bürokonzept, in dem sich die fortschrittlichsten Technologien mit einem wiedergefundenen Bewußtsein für das Wohlbefinden und die Natur vermischen. Prestige, das keine oberflächliche Schaustellung ist, sondern im Gegenteil die Suche nach Harmonie, Liebe fürs Detail, geschmackvolle Zusammenstellung. Eine Einfachheit, die gründlichen Überlegungen entspringt und sich in wichtigen Kompositionen manifestiert und Intimität und Freundlichkeit in Arbeitssituationen schafft. Transparenz, Helligkeit, reine Formen, natürliche Essenzen: Das ist der Arbeitsplatz von heute und der Zukunft in der neusten Interpretation vom Projekt Frame +. Von Meetingräumen bis zum Managerbüro, zusammen mit den anderen Elementen der Kollektion Sintetica, um den Räumen, in denen wir jeden Tag arbeiten, mehr Tiefe, mehr Authentizität und mehr Emotionen zu geben.

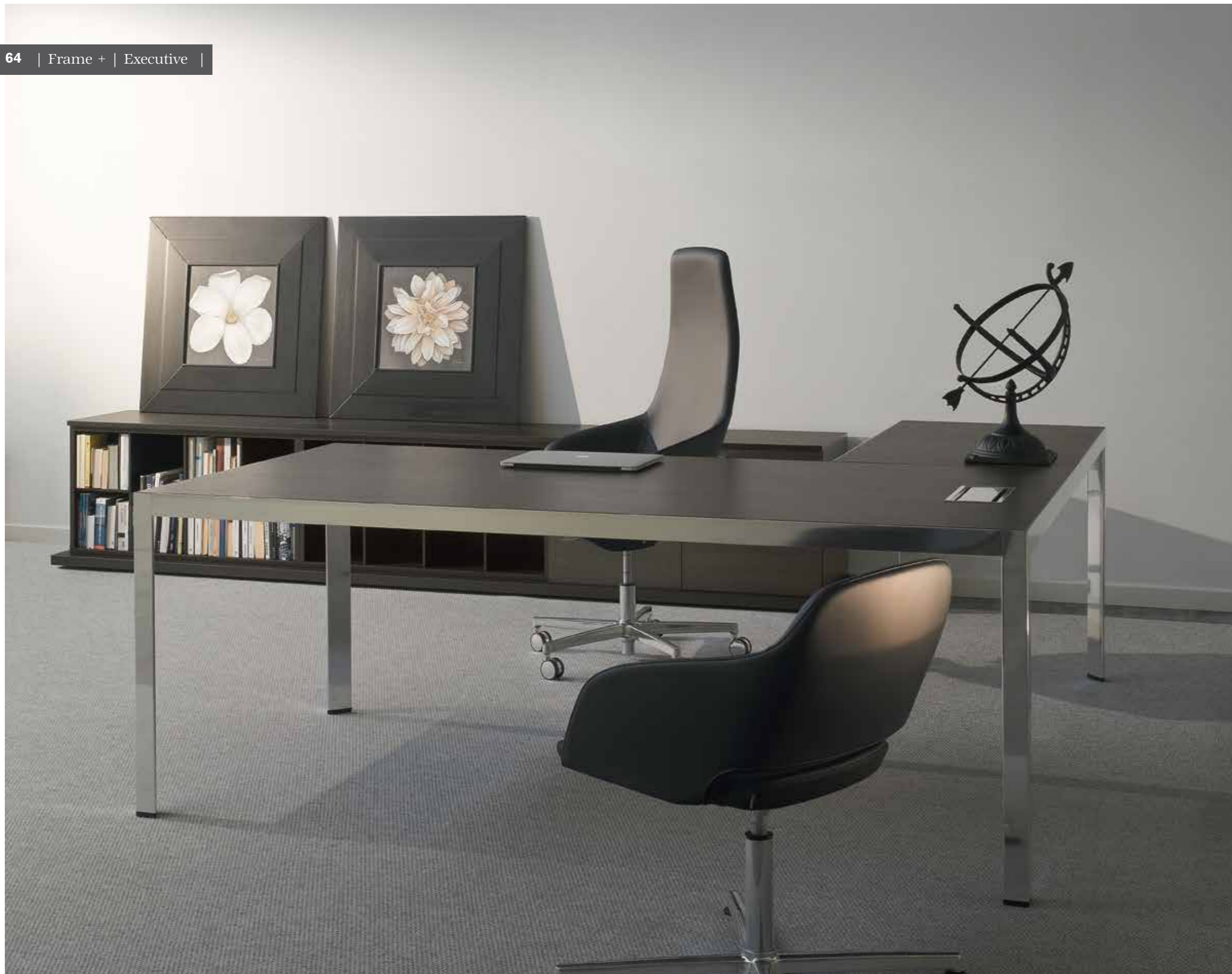

Un nuevo concepto de oficina, en el cual las tecnologías más avanzadas se funden con un renovado interés por el bienestar y la naturaleza. Un prestigio que no es la ostentación superficial, sino al contrario buscar la armonía, la atención a los detalles, el gusto por las combinaciones. Una simplicidad que nace de un estudio a fondo y que se manifiesta en composiciones importantes, así como en situaciones de trabajo íntimas y acogedoras.

Transparencia, luminosidad, formas puras, esencias naturales: es el espacio de trabajo del presente y del futuro, en una interpretación del proyecto Frame +.

Desde entornos de reuniones a situaciones de dirección, junto a otros elementos de la colección Sinetica, para dar valores más profundos, más auténticos y más emocionantes a los espacios en los cuales trabajamos cada día.

#Dimensions & Finishes





Vasca cablaggio semplice. Cable tray. Bac cablag. Kabelwanne. Bandeja para el cableado simple.

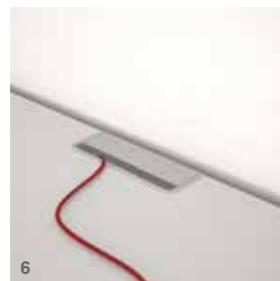

Passacavi. Outlet. Obturateur. Kabelauslass. Pasacables.



Carter di copertura. Protective cover. Carter de couverture. Abdeckung. Carted de cobertura.

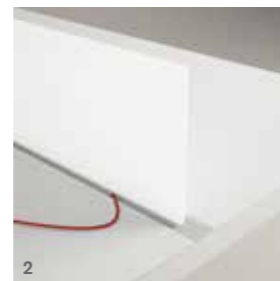

Screen. Screen. Cloisonette. Screen. Screen.



Colonnine. Vertical cable management. Pied partagé. Stützfüessen. Torre/columnas.



Carter. Carter. Carter. Abdeckung. Carter.



Porta CPU scatolato. Cpu holder. Support uc fermé. Geschlossener CPU Halterer. Leca cpu embalado.



Classificatore. Filing drawer. Caisson pour dossier suspendu. Container fuer Haengeregistratur. Clasificador.



Interno cassetto PVC. Internal pvc drawer. Interieur du tiroir en pvc. Schublade innen aus PVC gefertigt. Interior cajón pvc.



Interno cassetto metallo. Internal metal drawer. Interieur du caisson metal. Metall Schublade Innenseite. Interior cajón metal.

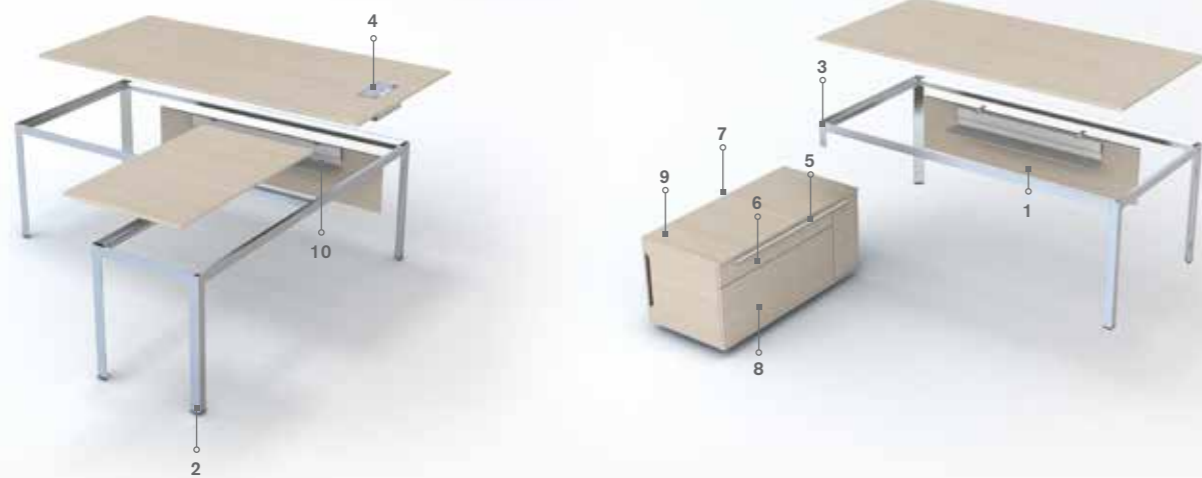

Porta CPU scatolato. Cpu holder. Support uc fermé. Geschlossener CPU Halterer. Lleca cpu embalado

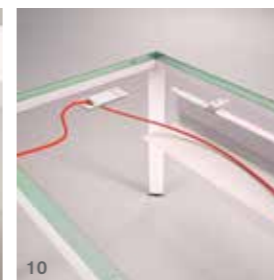

Canalizzazione. Wire management. Cablage. Verkabelung. Canalización.



Flap. Flap. Flap. Klappe. Solapa



Maniglia E. Handle E. Poignée E. Griffe E. Manija E.



Maniglia D. Handle D. Poignée D. Griffe D. Manija D.



Plug in. Plug in. Montiert. Elektrifizierungs- Modul. Enchufe.



Mobile di servizio portante. Supporting side unit. Meuble de retour porteur. Stand Technikcontainer.



Cassetto con vaschetta porta cancelleria. Drawer with pencil holder. Tirette porte accessoire. UtensilieSchublade. Cajón con puerta papelería.



Schiena removibile. Removable back panel. Dos removable. Herausnehmbar ruecken. Trasera desmontable.



Anta ribalta. Flap opening door. Porte rabattable. Klapptuer. Puetra basculante.



Modesty. Modesty. Panneau de facade. Frontblende. Faldon.



Dattilo. Return desk. Retour. Ansatz Tisch. Apéndice.



Colonnine. Vertical cable management. Pied partagé. Stützfuessen. Torre/columnas.



Carter. Carter. Carter. Abdeckung. Carter.



Maniglia E. Handle E. Poignée E. Griffe E. Manija E.



Maniglia D. Handle D. Poignée D. Griffe D. Manija D.



Vaschetta porta accessori. Accessories tray. Plumier. Utensilienschale. Bandeja lleva accesorios.



Interno cassetto PVC. Internal pvc drawer. Interieur du tiroir en pvc. Schublade innen aus PVC gefertigt. Interior cajón pvc.



Interno cassetto metallo. Internal metal drawer. Interieur du caisson metal. Metall Schublade Innenseite. Interior cajón metal.



Classificatore. Filing drawer. Caisson pour dossier suspendu. Container fuer Haengeregistratur. Clasificador.



12

11

Operative

160 x 80 x 74 cm
180 x 80 x 74 cm
200 x 80 x 74 cm



320 x 80 x 74 cm
360 x 80 x 74 cm
400 x 80 x 74 cm



160 x 165 x 74 cm
180 x 165 x 74 cm
200 x 165 x 74 cm



320 x 165 x 74 cm
360 x 165 x 74 cm
400 x 165 x 74 cm



320 x 165 x 74 cm
360 x 165 x 74 cm
400 x 165 x 74 cm



480 x 165 x 74 cm
540 x 165 x 74 cm
600 x 165 x 74 cm



Executive

200 x 100 x 74 cm



200 x 200 x 74 cm



246 x 202 x 74 cm



Meeting

220 x 120 x 74 cm



320 x 120 x 74 cm



440 x 120 x 74 cm



165 x 165 x 74 cm



330 x 165 x 74 m



495 x 165 x 74 cm



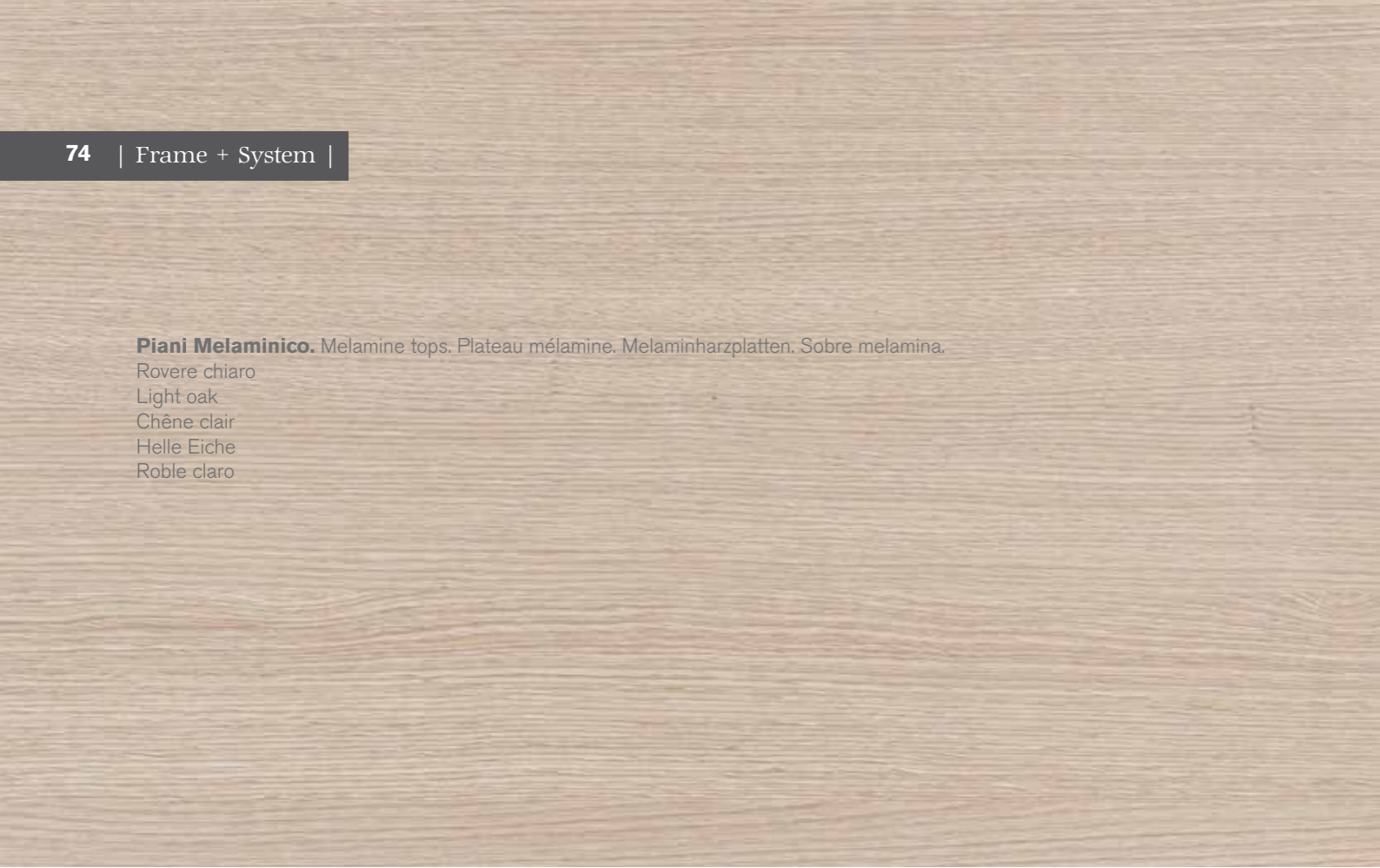

Piani Melaminico. Melamine tops. Plateau mélamine. Melaminharzplatten. Sobre melamina.
 Rovere chiaro
 Light oak
 Chêne clair
 Helle Eiche
 Roble claro



Piani Melaminico. Melamine tops. Plateau mélamine. Melaminharzplatten. Sobre melamina.
 Rovere scuro
 Dark oak
 Chêne foncé
 Dunkel Eiche
 Roble oscuro

Screen. Screen. Panneau écran. Screen. Screen.

Tessuto
 Fabric
 Tissu
 Gewebe
 Tejido

Vetro
 Glass
 Verre
 Glas
 Cristal

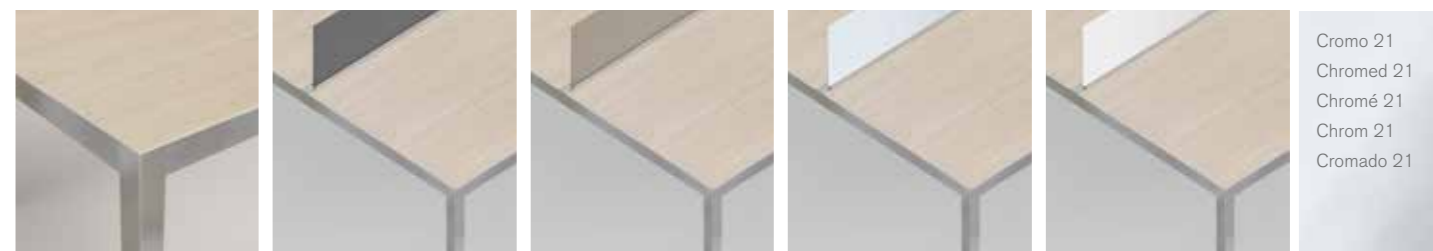
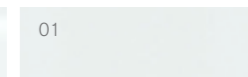

Cromo 21
 Chromed 21
 Chromé 21
 Chrom 21
 Cromado 21



Bianca 01
 White 01
 Blanc 01
 Weiße 01
 Blanco 01

Screen. Screen. Panneau écran. Screen. Screen.

Tessuto
 Fabric
 Tissu
 Gewebe
 Tejido

Melaminico
 Melamine
 Mélamines
 Melaminbeschichtung
 Melamina

Vetro
 Glass
 Verre
 Glas
 Cristal

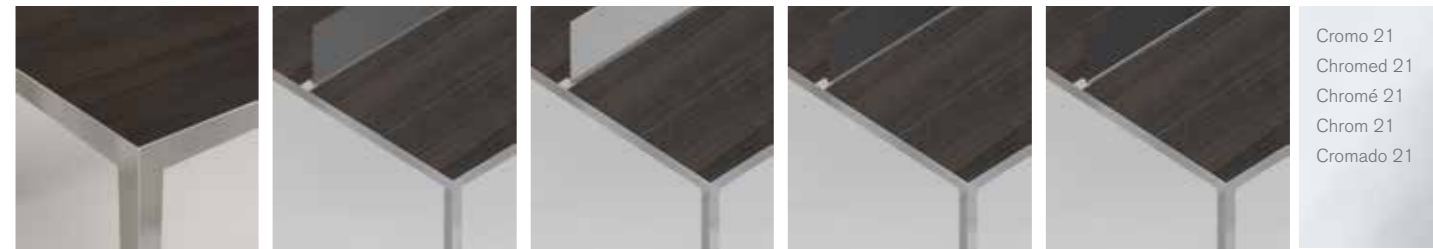

Cromo 21
 Chromed 21
 Chromé 21
 Chrom 21
 Cromado 21



Piani Melaminico. Melamine tops. Plateau mélamine. Melaminharzplatten. Sobre melamina.

- Noce scuro
- Dark walnut
- Noier foncé
- Dunkel Walnuss
- Nuez oscuro

Screen. Screen. Panneau écran. Screen. Screen.

Tessuto
Fabric
Tissu
Gewebe
Tejido

Vetro
Glass
Verre
Glas
Cristal

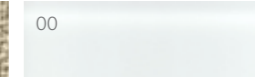

- Cromo 21
- Chromed 21
- Chromé 21
- Chrom 21
- Cromado 21



- Bianca 01
- White 01
- Blanc 01
- Weiße 01
- Blanco 01



Piani Melaminico. Melamine tops. Plateau mélamine. Melaminharzplatten. Sobre melamina.

- Faggio naturale
- Natural beech
- Hêtre naturel
- Buche natur
- Haya natural

Screen. Screen. Panneau écran. Screen. Screen.

Tessuto
Fabric
Tissu
Gewebe
Tejido

Vetro
Glass
Verre
Glas
Cristal

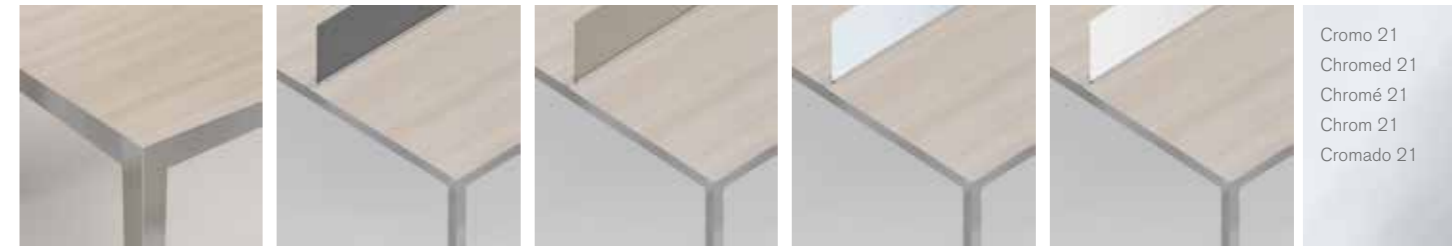
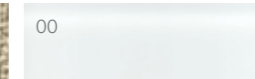

- Cromo 21
- Chromed 21
- Chromé 21
- Chrom 21
- Cromado 21



- Bianca 01
- White 01
- Blanc 01
- Weiße 01
- Blanco 01

Piani Melaminico. Melamine tops. Plateau mélamine. Melaminharzplatten. Sobre melamina.

Bianco
White
Blanc
Weiße
Blanco

Piani Melaminico. Melamine tops. Plateau mélamine. Melaminharzplatten. Sobre melamina.

Noce
Walnut
Noyer
Nüßbaum
Nuez

Screen. Screen. Panneau écran. Screen. Screen.

Tessuto
Fabric
Tissu
Gewebe
Tejido

Vetro
Glass
Verre
Glas
Cristal

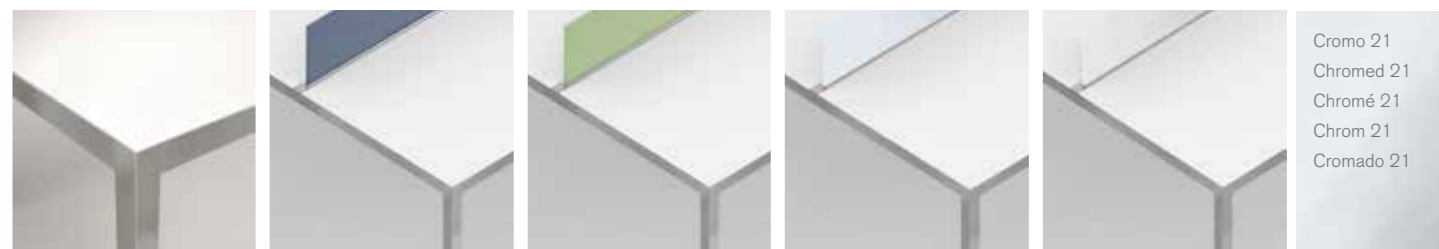
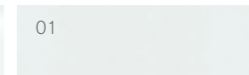

Cromo 21
Chromed 21
Chromé 21
Chrom 21
Cromado 21



Bianca 01
White 01
Blanc 01
Weiße 01
Blanco 01

Screen. Screen. Panneau écran. Screen. Screen.

Tessuto
Fabric
Tissu
Gewebe
Tejido

Vetro
Glass
Verre
Glas
Cristal

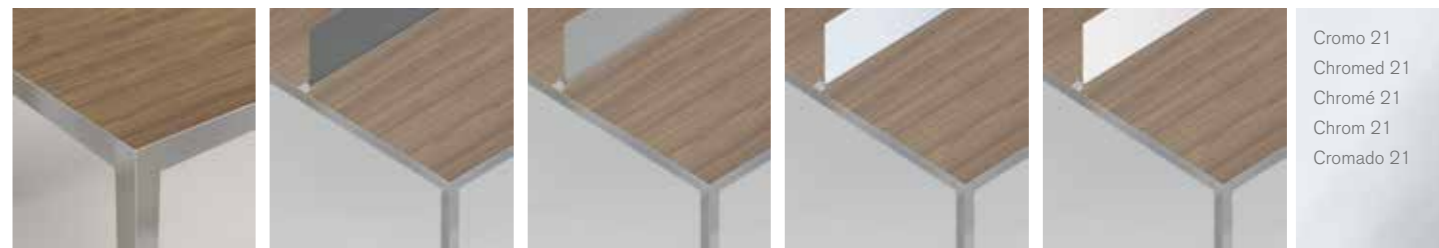
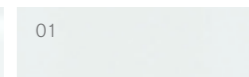
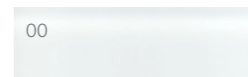

Cromo 21
Chromed 21
Chromé 21
Chrom 21
Cromado 21



Bianca 01
White 01
Blanc 01
Weiße 01
Blanco 01

Essenze. Veneer. Ébénisterie. Furnierte. Madera.

Ebano
Ebony
Ebéne
Ebenholz
Ebano

Essenze. Veneer. Ébénisterie. Furnierte. Madera.

Noce
Walnut
Noyer
Nüßbaum
Nuez

Essenze. Veneer. Ébénisterie. Furnierte. Madera.

Wengé



Cromo 21
Chromed 21
Chromé 21
Chrom 21
Cromado 21



Cromo 21
Chromed 21
Chromé 21
Chrom 21
Cromado 21



Bianca 01
White 01
Blanc 01
Weiße 01
Blanco 01



Cromo 21
Chromed 21
Chromé 21
Chrom 21
Cromado 21



Bianca 01
White 01
Blanc 01
Weiße 01
Blanco 01



Cromo 21
Chromed 21
Chromé 21
Chrom 21
Cromado 21



Cromo 21
Chromed 21
Chromé 21
Chrom 21
Cromado 21

Piani vetro. Glass tops. Plateau verre. Glas. Sobre cristal.

Bianco
White
Blanc
Weiße
Blanco

Piani vetro. Glass tops. Plateau verre. Glas. Sobre cristal.

Nero
Black
Noir
Schwarz
Negro

Operative

Workstation Workstation. Plateau compact. Eckschreibtisch. Mesa operativa.

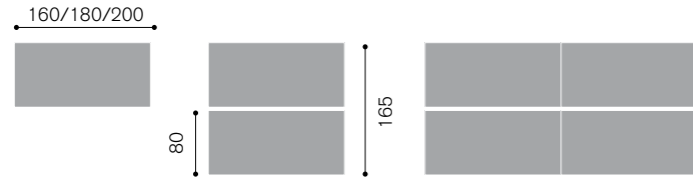

Screens Screen. Panneaux écran. Screen. Screen.

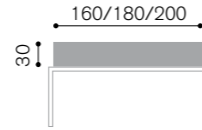

Struttura Frame. Structure. Gestell. Patas.



Executive

Workstation Workstation. Workstation. Workstation. Workstation.

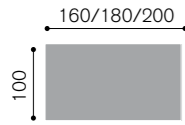

Estensioni Length features. Extensions. Erweiterungen. Extensiones.

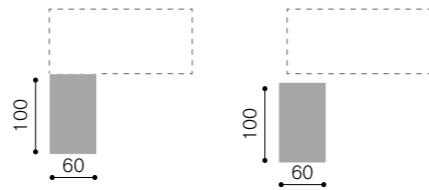

Struttura Frame. Structure. Gestell. Patas.

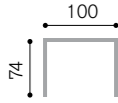

Modesty Panneau de facade. Frontblende. Faldon.

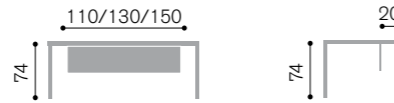

Meeting

Piani Tops. Plateaux. Platten. Sobre.

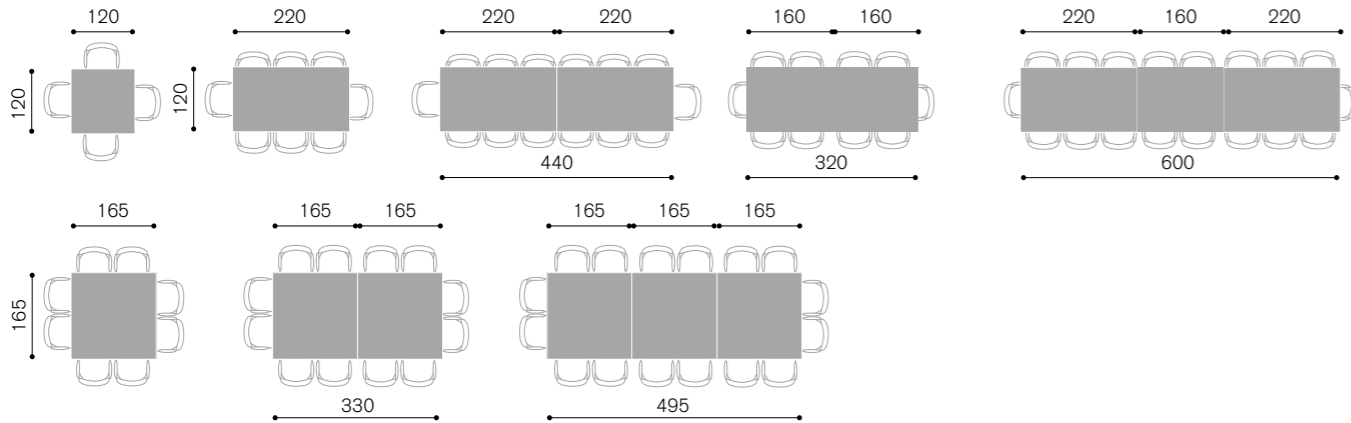

Cassettiere - Contenitori Drawers. - Cabinets. Caissons. - Rangement. Rollcontainer. - Schränke. Cajoneras. - Contenedores.

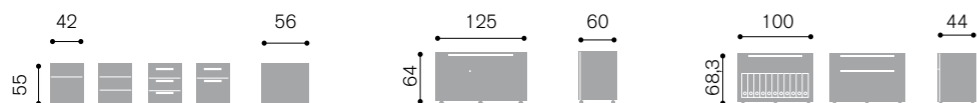

Finiture Finishes. Finitions. Ausführungen. Acabados.

Piani Melaminico
Melamine tops
Plateau mélamine
Melaminharzplatten
Sobre melamina

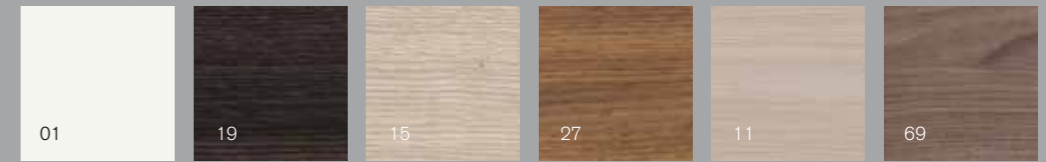

Piani Legno
Wood tops
Plateau bois
Holzplatten
Sobre madera



Piani Vetro
Glass tops
Plateau verre
Glasharzplatten
Sobre vidrio

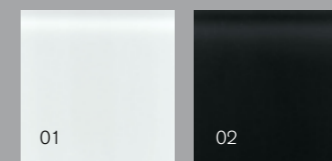

Struttura
Frame
Structure
Gestell
Patas

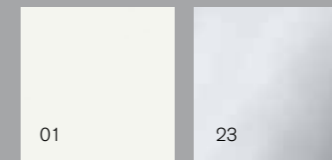

Screen Tessuto¹
Fabric screen
Panneau écran en tissu
Gewebe screen
Screen en tabizado

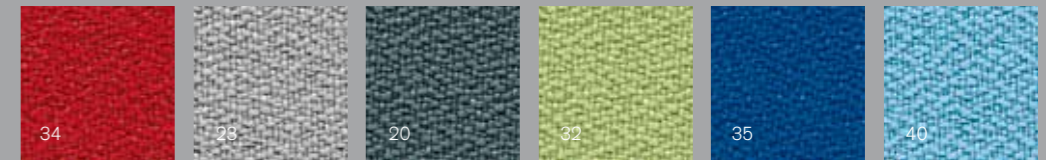

Screen Melaminico
Melamine screen
Panneau écran mélamine
Melamin screen
Screen melaminico

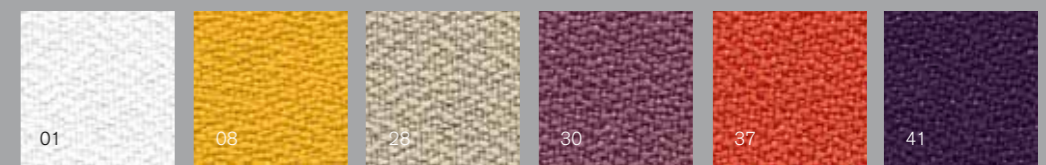

Screen Vetro
Glass screen
Panneau écran en verre
Glas screen
Screen en vidrio



Accessori
Accessories
Accessoires
Zubehoeren
Accesorios



1 Colori standard da cartella Lucia per colori e tipologia tessuti diverse, visionare cartelle tessuto o contattare l'ufficio commerciale. Standard colours as Lucia folder. For different colours and fabric typologies, please check the fabric folder or alternatively contact the sales department. Finitions standard selon famille Lucia. Pour finitions et typologie de tissu différentes, merci de contacter le service commerciale. Standard Farben wie Lucia Karte. Für sonderen Typologie und Farbe von Stoff, sehen Sie bitte die Stoffkarte oder setzen Sie sich in Verbindung mit Einkaufs-Büro. Por colores y tipología tejido diferentes, visionar carpetas tejidos o contactar el despacho comercial.

Concept & Art Direction:

Sinetica Lab

Graphic Design:

Fabio Zoratti

Photo:

Beppe Raso

Stylist:

Carin Scheve from p. 8 to p.27

Sinetica Lab from p. 40 to p. 65

Rendering:

Studio Simula from p. 68 to p. 71

Sinetica Lab rom p. 72 to p. 82

Copy:

Daniele Varelli

Translate by:

Transitus Group

Color separation:

Lucegroup.it

Made and printed in Italy by:

GFP.it

Special thanks to all those who have worked towards the success of this catalogue.

Lighting in collaboration with Macrolux srl
from page 8 to 27 and page 58 and 63

For further information, we invite you to visit our web site
www.sinetica.com

To have fun follow us on
www.whitespace.sineticaindustries.com

1^a Edition 06/13

All right reserved - All intellectual property rights, such as trademarks, patents and copyrights are reserved.

Nothing contained in this brochure may be reproduced without written permission.

Copyright 2013

© **Sinetica Industries srl**

Sinetica Industries srl
Via Plinio Fabrizio, 20
31046 Oderzo TV, Italy
T +39 0422 501611
F +39 0422 501679
www.sinetica.com



The mark of
responsible forestry

Su richiesta Sinetica
può fornire materiale
certificato FSC ®.
On request Sinetica
could supply FSC ®
certified material.



Cert. n° 7672 Certificazione ISO 9001
Cert. n° 7672 Certificazione ISO 14001

Sinetica Industries Srl si riserva il diritto di apportare, senza preavviso, ogni modifica mirata al miglioramento funzionale e qualitativo dei propri prodotti. Testi e disegni presenti in questo stampato hanno scopo divulgativo: per ogni aspetto tecnico fare riferimento ai listini aziendali e relativi aggiornamenti. I campioni di colori e materiali hanno valore indicativo.

Sinetica Industries Srl reserves the rights at all time to apply modifications for the functional or qualitative improvement of its products. Texts and drawings present in this brochure have a divulgative purpose: for every technical aspect please refer to the company's price lists and their relative updates. The colour and material samples have an indicative value.

